

(4) 3/4" DIA FOR 5/8" HOLD DOWN BOLTS

SWITCHES NOT SHOWN FOR CLARITY

NOTES:

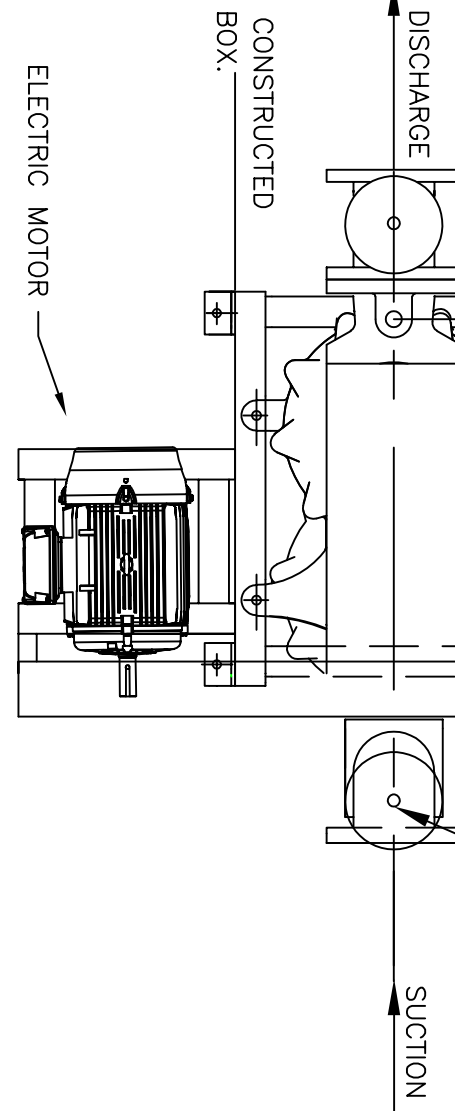

PUMP FRAME IS CONSTRUCTED OF SS304 2 1/2" BOX.

ELECTRIC MOTOR

- 1- HEIGHTS SHOWN ARE PVP STANDARDS PUMP CENTERLINE HEIGHTS CAN BE RAISED OR LOWERED.
- 2- SWITCHES AND DAMPENERS ARE OPTIONAL. CHECK BUILD SHEETS FOR EQUIPMENT SUPPLIED.
- 3- FLEX JOINTS NOT RECOMMENDED
- 4- WHEN INSTALLING PUMP KEEP AREA UNDER PUMP CLEAR FOR MAINTENANCE
- 5- SWAN NECK CAN ROTATE 90° LEFT OR RIGHT
- 6- MOTOR CAN BE MOUNTED ON THE RIGHT OR LEFT SIDE
- 7- TO REMOVE BELT GUARD, 40-INCHES IS REQUIRED ABOVE THE PUMP. COVERS CAN BE SPLIT TO BE REMOVED HORIZONTALLY

TOTAL EQUIP. WEIGHT = 1900 LBS
WT. W/O DAMPENERS = 1180 LBS

REV	DESCRIPTION	DATE	BY
0	INITIAL RELEASE	9/16/2020	ABB

NOTES MATERIAL: -----

REVISION HISTORY

THIS DRAWING AND ALL INFORMATION IS THE PROPERTY OF

PVP
Penn Valley Pump

PENN VALLEY PUMP CO., INC.
998 EASTON ROAD - WARRINGTON, PA 18976
PHONE: (215) 343-8750 www.pennvalleypump.com

ALL INFORMATION CONTAINED IN THIS DOCUMENT IS BOTH CONFIDENTIAL AND PROPRIETARY TO PVP. NO LICENSE, EXPRESSED OR IMPLIED, UNDER ANY PATENT, COPYRIGHT, OR TRADE SECRET IS GRANTED OR IMPLIED BY THE CONVEYANCE OF THIS DOCUMENT. NO PART OF THIS DOCUMENT MAY BE REPRODUCED, TRANSMITTED, STORED IN A RETRIEVAL SYSTEM, TRANSLATED TO ANY LANGUAGE OR COMPUTER LANGUAGE, IN ANY FORM BY ANY MEANS ELECTRONIC, MECHANICAL, OR OTHERWISE.	SCALE: N/A
CUSTOMER: Penn Valley Pump	DATE: 9/17/2020
LOCATION: Internal	DR. BY: -
TITLE: 6DDSX76 Side Mount	PLOT DATE: -
	DRAWING NO. PVD769
	SHEET 1 OF 1